

MEX



purebeam



DISHWASHER DV813DX

FREE STANDING DISHWASHER
60cm. | Dark Inox

EAN
8858787029484

PRICE
THB 41,900.-

Unit price in THB is
inclusive of 7% VAT.

8 POWERFUL WASHING PROGRAMS

- Jet Wash 14 min
- Quick 30 min 40°C
- Eco
- Dual Pro Wash 60°C
- Super 50 min 65°C (Quick Clean)
- Smart 30°C - 50°C
- Smart 50°C - 70°C
- Steam Wash

Jet Wash

With this fast program, you can clean the dishes like less and/or recently soiled (coffee, milk and tea etc.) in only 14 min. This program is one of the fastest programs in the world. It cleans your dishes with 4 place settings capacity in 14 min.

DualPro Wash

Advanced pump technology allows for one wash to be cleaned at two separate water pressures. Baked on food does not stand a chance in the bottom while the delicate glasses in the top are gently being washed.

Smart Wash

Turbidity sensor detects the amount of turbidity in water and adjusts the washing cycle parameters (temperature, duration, amount of water) accordingly.

Steam Wash

Steam wash technology softening the most stubborn dirt by steam power. High temperature and directly applied steam ensure perfect hygiene and gentle cleaning for your sensitive dishes.



PLUS 3 EXTRA FUNCTIONS

Extra Hygienic Wash

Extra hygiene ensures a maximum hygiene with high temperature washing. It increases water temperature at final rinse step in order to eliminate bacteria up to 99.99%.

Extra Dry

For better drying performance, MEX dishwasher provide extra drying function which it increases water temperature at final rinse step and drying step duration up to 10 minutes.

Extra Silent

It is possible to have more silent washing with variable speed motor technology. Extra silent function decreases noise level of program without decreasing cleaning quality in day or night time when silence is required.

Extra Fast

Extra fast function decreases program duration while it is increasing water temperature and pressure to ensure high washing quality in a shorter duration.



PEN K

PEN K INTERTRADING CO.,LTD.
Kitchen Appliances Business Unit

Showroom
+66 2 714 0785-6
contract@penk.co.th

Sales and Marketing
+66 2 493 6565
contact2@penk.co.th

Service Center
+66 2 493 6565
service2@penk.co.th

www.mexappliance.com
mexappliance
@mexappliance

FREE STANDING DISHWASHER DV813DX

LATEST IN DISH-CLEANING TECHNOLOGIES

MEX DV813DX dishwasher are engineered to the high standards with latest technologies.



purebeam TECHNOLOGY

UV feature prevents bacterial growth and reduce the bacteria remaining after washing cycle. It disinfects the load using UV technology built into machine, automatically sterilizing each load before unload. It will be a real easiness for parents with babies.



Natural Ion Tech spreads negative ions inside the dishwasher. These negative ions neutralize particles of unpleasant smell. Natural Ion Tech removes odors caused by dirty dishes.

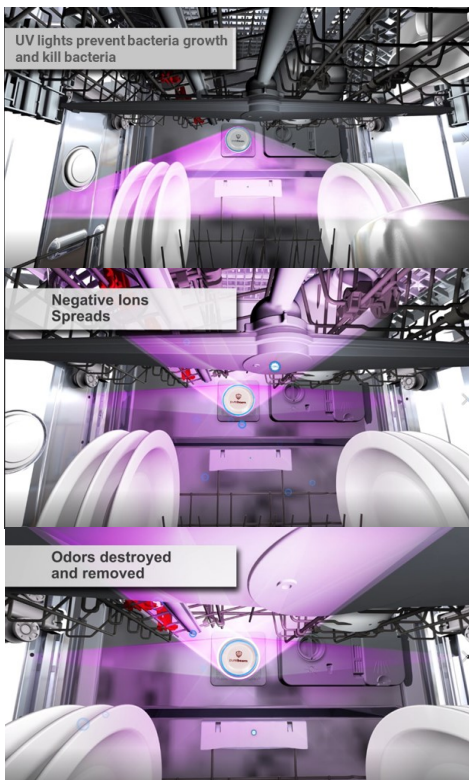

OFFERING MORE EXCELLENT OPTIONS



Half Load

Eco Friendly Half Load technology provides washing performance when dishwasher is not fully loaded, only lower basket or upper basket or both are used. It can run with reduced water and energy consumption. Half Load technology saves energy and water reducing energy and water consumption due to load options.



Tablet Option

With this option, water reaches optimum temperature to dissolve and combined detergent ideally and eliminates such drawbacks and assures maximum performance when tablet detergents are used.



Delay Timer

The start time of a program can be delayed, e.g. to benefit from economy rates of electricity. A delay start time of between 1 hour and 24 hours can be selected.



Child Lock

Child lock option never allows your children to play with your dishwasher. It allows you to lock the buttons on the control panel to be able to restrict the functionality of buttons.



FREE STANDING DISHWASHER DV813DX

HIGH CAPACITY

With full capacity as 13 place settings, you can easily load the dishes for the entire family. Adjustable baskets and foldable racks help customize the capacity which means more dishes can be placed.



FLEXIBLE BASKETS AND RACKS

The ideal place settings for every need is complete in this dishwasher.

The Lower Basket is more comfortable with folding racks on it that each section can be folded separately. They give more room inside the washing compartment that enable placement for large items such as pots and pans.

The Upper Basket is easily adjustable with 3 step level height to maximize space when washing tall items. There are also adjustable mug selves making more flexibility to fit tall glasses, mugs and smaller cups.

The 3rd Rack provides perfect extra space for loading utensils, cutlery and silverware. It is composed of two pieces which can be taken out left or right part of the 3rd rack to obtain more space for the dishes in the upper basket.



	Upper Basket Position ↓	Upper Basket Position ↑	w/o height adjustment
○ Max. Plate Dimension for Upper Basket	19,5 cm	14,5 cm	14,5 cm
○ Max. Plate Dimension for Lower Basket	26,5 cm	31,5 cm	31,5 cm



3rd Rack



Upper Basket



Removable Cutlery Basket



Lower Basket

FREE STANDING DISHWASHER DV813DX



CLEANING LESS WITH ANTI-FINGERMARK

Finishing of MEX DV813DX dishwasher door is fingerprint-resistant stainless steel. It helps guard against fingerprints and making the dishwashing door easy to clean.

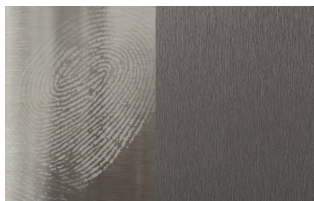

SIMPLY TOUCH, MONITOR AND CONTROL

LED display on DV813DX is large and wide touch control panel making your cleaning day enjoy. It is easy to touch and read allowing quicky check status, setting, remaining time and cycle progress at a glance.



INTERIOR LED LIGHTING

4 spots interior lighting in this MEX DV813DX allows to see all items and utensils in the washing compartment, make loading and unloading a much more pleasant task.



ULTIMATE IN QUIETNESS

This DV813DX dishwasher offers high quality standard in quietness, efficiency and design. With an ultra quiet **41 dB** noise level, it remains great cleaning abilities and feature rich functionality while keeping your house as peaceful as can be.

HEATER SAFETY PROTECTION

In case of lack water, with the help of pressure switch, the resistance is prevented from being in operation. So both the resistance and the machine itself are protected.

OVERFLOW AND LEAKAGE PROTECTION

Aquastop in the dishwasher activates overflow mode when there is too much water in the dishwasher and the excess water get is drained. It also detects leaks in the base of dishwasher, shut down operation and automatically pumps out water before reaching to floor. The unit can auto reset the overflow mode until the water level in the basement cover reaches a certain level.



ANTI-BACTERIAL FILTER

The Anti-Bacterial Filter in MEX dishwashers performs an antimicrobial treatment in the filter to effectively inhibit micro-organism build-up inside your dishwasher at all times.



Top Nozzle



Impeller



Anti-Bacterial Filter

FREE STANDING DISHWASHER DV813DX

FEATURES

MEX dishwasher stands out in style and fits right into your kitchen whereas providing the best washing result for all your everyday cooking and dining utensils. It makes your dish-cleaning is easier than ever.

- 60 cm. free standing dishwasher
- PureBeam Technology prevents bacterial growth and reduce the bacteria remaining after washing cycle
- Ion Technology removes odors caused by dirty dishes
- 13 place settings
- 2 baskets and 3rd rack (adjustable upper basket with foldable racks) with a removable cutlery basket
- 8 washing programs
 - Jet Wash 14 min.
 - Quick 30 min 40°C
 - Eco
 - Dual Pro Wash 60°C
 - Super 50 min 65°C (Quick Clean)
 - Smart 30°C–50°C
 - Smart 50°C–70°C
 - Steam Wash
- Plus 4 extra functions
 - Extra Hygienic Wash
 - Extra Dry
 - Extra Silent
 - Extra Fast
- Half Load function that saves energy and water
- A delay start time of between 1 hour and 24 hours can be selected.
- Wide LED display with touch control
- Rinse-aid, salt use, washing cycle and end of cycle indicator light
- Child safety lock
- 4 interior lighting
- Anti-Bacterial Filter
- Standard program water consumption : 9 liter / cycle
- Superior energy efficiency (Class A++) for saving water and electricity
- High cleaning efficiency (Class A)
- Drying efficiency class A
- Silent wash at noise level of 41 dB
- Made in Europe

SPECIFICATION

PRODUCT MEASUREMENT

Overall Dimension	W598 x D598 x H850 mm.
Net Weight	46.0 Kg.

PACKAGING MEASUREMENT

Overall Dimension	W660 x D675 x H886 mm
Gross Weight	49.0 Kg.

IMPORTANT SAFTY INFORMATION

Power Supply	220-240V / 50Hz.
Nominal Power	1.9 kW

ISOMETRIC VIEW

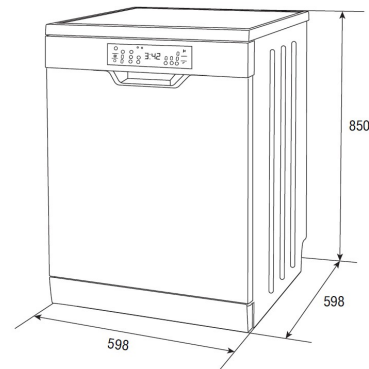

INSPIRATION

